



## Model NV-218A-PVD

### Video Transceiver



#### Features:

- Power-Video-Data (PVD™) signals are routed via UTP and RJ45 or screwless terminal block for organized pass-through of inputs/outputs
- Mini-coax pigtail supports in-camera mounting in most dome cameras
- Use with NVT's PVD™ Power Supply Hubs and Cable Integrators
- Up to 3,000ft (1km) with a NVT DigitalEQ™ Hub or active receiver, (see Power Distance Chart)
- Up to 1,500ft (460m) with a NVT StubEQ™ Hub
- Exceptional interference rejection
- Built-in transient protection
- Limited lifetime warranty

The NVT Model NV-218A-PVD Video Transceiver with Power and Data is a passive (non-amplified) device that allows the transmission of real-time monochrome or color video over Unshielded Twisted-Pair (UTP) telephone wire. Baseband (composite) signals of any type are supported.

This new product incorporates the transceiver engine of NVT's popular NV-214A-M video transceiver with the added value of Power and Data connections to and from the camera. Power, Video and Data are routed via UTP and RJ45 or screwless terminal block inputs/outputs. Used at the camera, the passive NV-218A-PVD has a 9" mini-coax pigtail lead for direct video output connection from the camera. Along side this coax lead are two sets of screwless terminal blocks for quick pass through connections for your camera's Power and Data. On the "house" or output side of the product you have the option of using convenient screwless UTP connectors or the more efficient RJ45.

The unparalleled interference rejection and low emissions of the NV-218A-PVD allow video signals to co-exist in the same wire bundle as telephone, datacom, or low-voltage power circuits. This allows the use of a shared or existing cable plant. The NV-218A-PVD carries a limited lifetime warranty and is UL and cUL listed.

#### Network Video Technologies

4005 Bohannon Drive • Menlo Park, CA 94025 • USA  
(+1) 650.462.8100 • 800.959.9870 • FAX (+1) 650.326.1940  
nvt.com • info@nvt.com



# Model NV-218A-PVD

## Video Transceiver

### Technical Specifications

#### WIRE DISTANCE (Power Distance Chart)

Supply voltage, wire resistance and minimum camera operating voltage determine the maximum camera distance. Examples assume a minimum 21VAC at the camera:

P/T/Z 24VAC Camera	NV-218A-PVD	
Power Supply Voltage	24 VAC	28 VAC
Minimum Voltage at Camera	21 VAC	21 VAC
P/T/Z Camera 1,000 mA, 2.4 W		
2-pair 24 AWG	90ft (27m)	210ft (64m)
2-pair 23 AWG (Cat6)	113ft (35m)	265ft (81m)

Fixed 12VDC Camera	NV-218A-PVD	
Power Supply Voltage	12 VDC	
Minimum Voltage at Camera	11.5 VDC	
B&W Camera 200 mA, 2.4 W		
2-pair 24 AWG	23m (75ft)	
2-pair 23 AWG (Cat6)	29m (94ft)	
Color Camera 400 mA, 4.8 W		
2-pair 24 AWG	11m (37ft)	
2-pair 23 AWG (Cat6)	14m (47ft)	
Color Camera 600 mA, 7.2 W		
2-pair 24 AWG	8m (25ft)	
2-pair 23 AWG (Cat6)	10m (31ft)	

**Notes:** Wire should be Cat5 or better/ low voltage camera power, video and RS-422 or RS-485 data may reside within the same wire bundle, however do not run 24 or 28VAC within the same wire bundle as other telecom or datacom signals.

#### VIDEO

Frequency response	DC to 5 MHz
Attenuation	0.5 dB typ
Common-mode / Differential-mode rejection 50 KHz to 5 MHz	60 dB typ
Impedance	
Coax, male BNC	75 ohms
UTP, Screwless terminal block	100 ohms
UTP RJ45 Data Connector	100 ohms

#### RJ45 PINOUTS

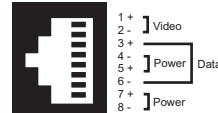

#### WIRE TYPE

Network Wiring	One Unshielded Twisted Pair
	Terminal Block 24-16 AWG (0,5-1,31mm)
	RJ45 24-22 AWG (0,5-0,64mm)
Category Type	2 or better
Impedance	100 ± 20 ohms
DC Loop Resistance	52 ohms per 1,000ft (18 ohms per 100m)
Differential Capacitance	19 pF/ft max (62 pF/m max)

#### ENVIRONMENTAL

Temperature	-22 to +167°F (-30 to +75 °C)
Humidity (non-condensing)	0 to 95%
Transient Immunity	per ANSI / IEEE 587 C62.41

#### MECHANICAL

Body Length	1.50in (38mm)
Body Depth	0.85in (22mm)
Body Height	1.54in (39mm)
Pigtail Length	9in (228mm)
Weight	2.0oz (60g)

#### REGULATORY



Specifications subject to change without notice.

### Typical Applications

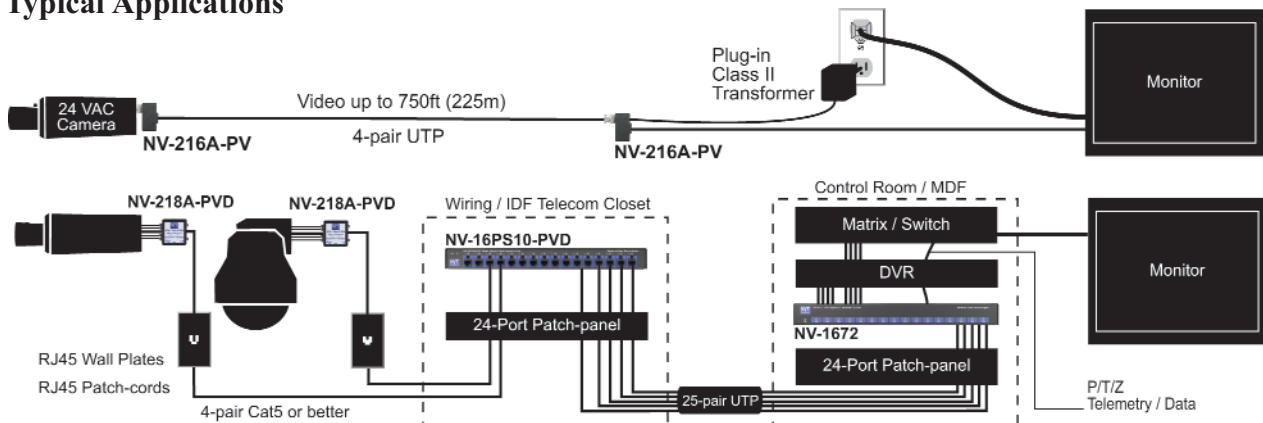

### Network Video Technologies

4005 Bohannon Drive • Menlo Park, CA 94025 • USA  
 (+1) 650.462.8100 • 800.959.9870 • FAX (+1) 650.326.1940  
 nvt.com • info@nvt.com